

Position Control Of Robot Arm Using Genetic Algorithm Based PID Controller

Majed D. Youns¹ , Salih M. Attya² , Abdulla I. Abdulla³
College of Electronics Engineering / University of Mosul /Mosul, Iraq
majiddhrar@yahoo.com¹, sm.attya@yahoo.com², abd_63om@yahoo.com³

Abstract

It is known that PID controller is used in every facet of industrial automation. The application of PID controller span from small industry to high technology industry. The aim of this paper is to design a position controller of a robot arm by selection of a PID parameters using genetic algorithm. The model of a robot arm is considered a third order system. And this paper compares two kinds of tuning methods of parameter for PID controller. One is the controller design by the genetic algorithm, second is the controller design by the Ziegler and Nichols method. It was found that the proposed PID parameters adjustment by the genetic algorithm is better than the Ziegler & Nichols' method. The proposed method could be applied to the higher order system also.

Keywords: Robot arm, Genetic algorithm(GA), PID controller, Ziegler-Nichols (ZN) Method.

التحكم على الموقع لذراع ألي باستخدام المسيطر التناسبي- التكاملية- التفاضلي بالاستناد إلى الخوارزمية الجينية .

د. ماجد ضرار يونس¹ ، صالح محمود عطية² ، عبد الله إبراهيم عبدالله³
مدرس ، مدرس مساعد ، مدرس مساعد
كلية هندسة الإلكترونيات / جامعة الموصل / الموصل / العراق

الخلاصة

من المعروف أن المسيطر التناسبي - التكاملية - التفاضلي يستخدم في كل جانب من جوانب الأتمتة الصناعية وكما يتم تطبيقه في مختلف تقنيات الصناعة. إن الهدف من هذا البحث هو تصميم المسيطر للسيطرة على الموقع الزاوي لذراع ألي. يتم اختيار ثوابت هذا المسيطر بالاستناد على تقنية الخوارزمية الجينية. الموديل الرياضي للذراع الألي تم اعتباره نظام من الدرجة الثالثة. يقارن هذا البحث بين نوعين من أساليب تنعيم ثوابت المسيطر. الأسلوب الأول باستخدام الخوارزمية الجينية أما الثاني تم باستخدام طريقة زيكلر - نكلس. من خلال مقارنة النتائج تبين إن الأسلوب الأول أفضل من الأسلوب الثاني. كما يمكن تطبيق الأسلوب الأول على نظام ذو درجة أعلى .

الكلمات الدالة: الذراع الألي، الخوارزمية الجينية، المسيطر التناسبي-التكاملية-التفاضلي، طريقة زيكلر-نكلس

Received: 6 – 6 - 2012

Accepted: 22 – 4 - 2013

1-Introduction:

In general, the arm of a robot has a number of joints .The current approach to the design of control system for robot joints is to treat each joint of the arm as a simple joint servomechanism, ignoring the effect of the movements of all other joints. In industrial robots, hydraulic or pneumatic actuators may be used rather than dc servomotors. Due to it's excellent speed and position control characteristic ,the dc servomotors has been widely used in industry ,therefore the actuator is assumed to be an armature-control dc motor . In addition it is assumed that the robot arm is connected to the motor through gears. Proportional-Integral-Derivative (PID) controllers have been widely used for speed and position control of robot arm. This paper endeavors to design a system using Genetic Algorithm (GA). Genetic Algorithm (GA) is a stochastic algorithm based on principles of natural selection and genetics. Genetic Algorithms (GAs) are a stochastic global search method that mimics the process of natural evolution. Using genetic algorithms to perform the tuning of the controller will result in the optimum controller being evaluated for the system every time. The objective of this paper is to show that by using the GA method of tuning a system , an optimization can be achieved. This can be seen by comparing the result of the GA optimized system against the classically tuned system.[6]

2- Robot Control System Model:

Fig(1).illustrate a single-joint robot arm. The block diagram of the robot joint control system is shown in Fig(2).[9] The robot arm is not affected by gravity and rigid. The dynamic behavior of the robot arm control system are given by the following equation.[8]

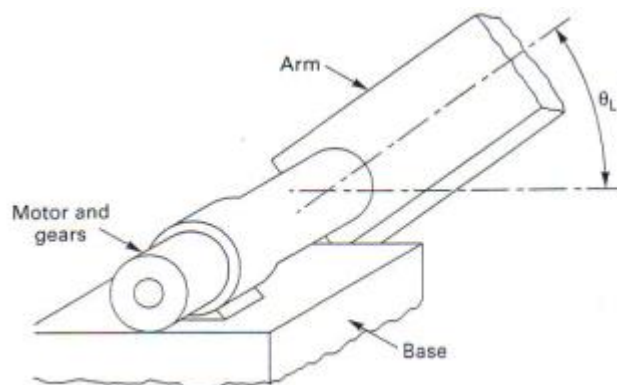

Fig(1). Single-Joint Robot Arm

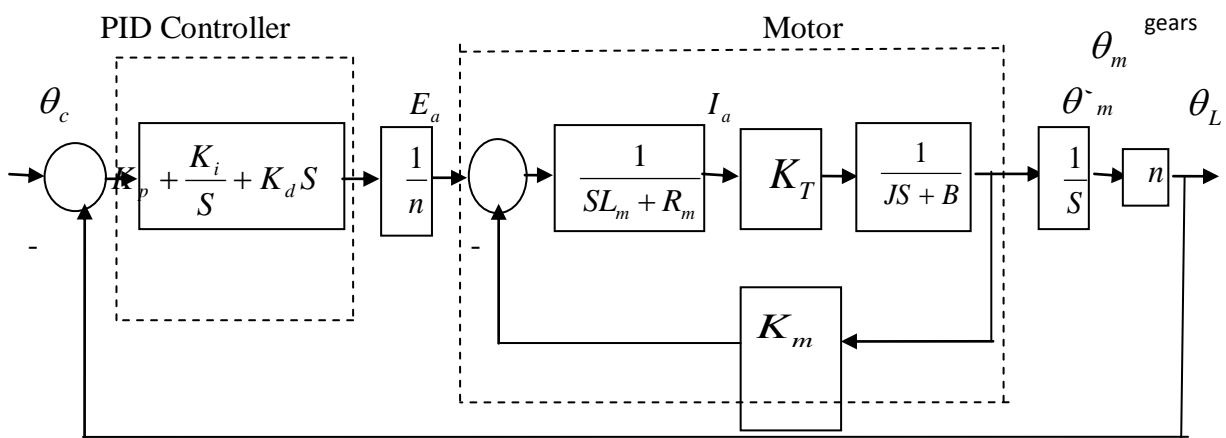

Fig(2). Robot Joint Control System

$$e_a(t) = R_m i_a(t) + L_m \frac{di_a(t)}{dt} + e_m(t) - \text{----- (1)}$$

$$e_m(t) = K_m \frac{d\theta_m(t)}{dt} \text{----- (2)}$$

$$T_m = K_T i_a(t) \text{----- (3)}$$

$$T_m = J \frac{d^2\theta_m(t)}{dt^2} + B \frac{d\theta_m(t)}{dt} \text{----- (4)}$$

$$J = J_m + n^2 J_l \text{----- (5)}$$

$$B = B_m + n^2 B_l \text{----- (6)}$$

$$\theta_L = n\theta_m \text{----- (7)}$$

After simplification and taking the ratio of $\theta_L(s)/E_a(s)$ we will get the transfer function as below.

$$\frac{\theta_L(s)}{E_a(s)} = \frac{K_T n}{JL_m S^3 + (R_m J + BL_m)S^2 + (K_T K_m + R_m B)S} \text{----- (8)}$$

Where.

R_m = armature- winding resistance in ohm.

L_m = armature - winding inductance in Henry.

i_a = armature - winding current in ampere.

e_a = armature voltage in volt .

e_m = back emf voltage in volt.

K_m = back emf constant in volt / (rad/sec)

T_m = torque developed by the motor in N.m

K_T = motor torque constant in N.m/A

J = moment of inertia of motor and robot arm in kg. m^2 /rad.

B = viscous - friction coefficient of motor and robot arm in N.m/rad /sec.

θ_m = angular displacement of the motor shaft in rad.

θ_L = angular displacement of the robot arm in rad.

θ_c = angular displacement of the reference input in rad.

n = gear ratio $\frac{N_1}{N_2}$

The robot arm control system under study has the following parameters.

$R_m = 21 \Omega$, $L_m = 2 \text{ H}$, $K_T = 38 \text{ N.m/A}$, $J = 2 \text{ kg.m}^2/\text{rad}$, $B = 1 \text{ N.m/rad/sec}$, $K_m = 0.5 \text{ V/(rad/sec)}$ and $n = 1/20$.

The block diagram of the servo control system for one of the joint of a robot is shown in Fig(3).[8]

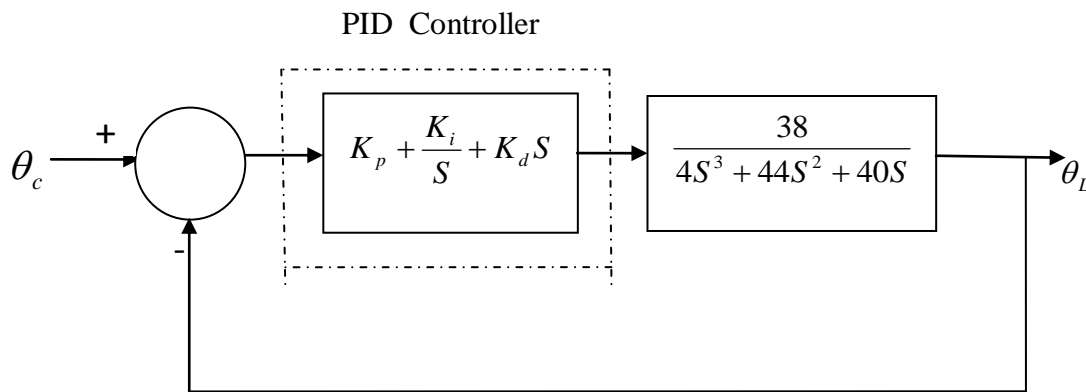

Fig.(3). Joint Control System For A Robot Arm .

3- Ziegler -Nichols Rule For Tuning PID Controller:

The control system performs poor in characteristics and even it becomes unstable, if improper values of the controller tuning constants are used. So it becomes necessary to tune the controller parameters to achieve good control performance with the proper choice of tuning constants. Controller tuning involves the selection of the values of k_p , K_i and K_d . By setting $K_i = 0$ and $K_d = 0$, we obtain the closed-loop transfer function. The value of k_p that makes the system marginally stable so that sustained oscillation occurs can be obtained by use of Routh's stability criterion. By examining the coefficients of the first column of the Routh table, we find that sustained oscillation will occur if $K_p = 11.57$. Thus the critical gain $K_{cr} = 11.57$. To find the frequency of oscillation (ω), we substitute $S = j\omega$ in the characteristics equation. From which we find $\omega = 3.16$ rad/sec. Hence, the period of sustained oscillation (p_{cr}) is $2\pi/\omega = 2$ sec. Referring to table 1, we determine K_p , K_i and K_d as follows[1]

$$K_p = 0.6 K_{cr} = 6.94, \quad K_i = 1.2 K_{cr}/P_{cr} = 6.94 \quad \text{and} \quad K_d = 0.075 K_{cr} * P_{cr} = 1.73.$$

Table 1 : Ziegler-Nichols Tuning Rule

Type of controller	K_p	K_i	K_d
P	$0.5K_{cr}$	0	0
PI	$0.45K_{cr}$	$0.54 K_{cr}/P_{cr}$	0
PID	$0.6K_{cr}$	$1.2 K_{cr}/P_{cr}$	$0.075 K_{cr} * P_{cr}$

The unit step response of the closed-loop system with PID controller can be obtained easily with MATLAB. The maximum overshoot is approximately 63%. The amount of maximum overshoot is excessive. It can be reduced by fine tuning the controller parameter. Such fine tuning can be made on the computer. The important thing to note here is that the Ziegler-Nichols tuning rule has provided a starting point for fine tuning. It is approximately twice the value suggested by the Ziegler-Nichols tuning rule.[1]

$$K_p = 15.26, \quad K_i = 6.94 \quad \text{and} \quad K_d = 8.39.$$

The transfer function of the PID controller is

$$G_c(s) = \frac{K_d S^2 + K_p S + K_i}{S}$$

Table 2 show the PID controller gain values

$$G_c(s) = \frac{8.39 S^2 + 15.26 S + 6.94}{S}$$

Table 2 : PID Controller Gain Values

Gain Coefficient	K _p	K _i	K _d
Values	15.26	6.94	8.39

From the above algorithm the step response of the system with conventionally PID controller is shown in Fig.(4) .

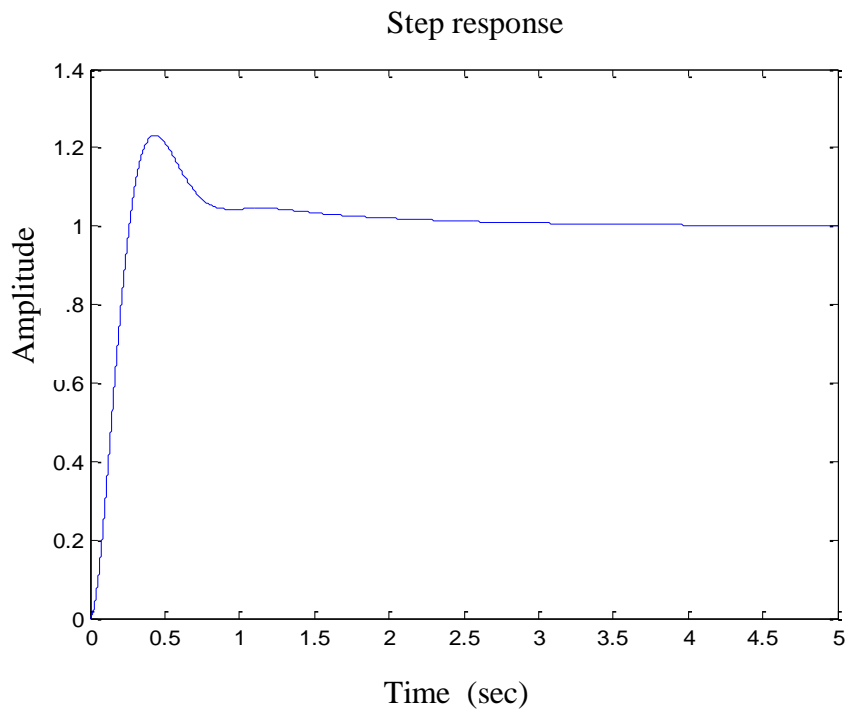

Fig(4).Response Of The System With Conventionally Tuned PID Controller

From the above step response ,we can analyze the following parameters ,Rise time ,Maximum overshoot and settling time .The rise time is about 0.2 sec .The Maximum overshoot of the system is approximately 23.9 % .Finally the settling is about 2 sec.[1]

From the analysis above ,the system has not been tuned to it's optimum .So in order to achieve the following parameter we have to go for Genetic algorithm approach. our system requirements are given in Table 3.[3]

Table 3 : System Requirements

System Specification	Max Over Shoot	Rise Time (Sec)	Settling Time (Sec)
	< 15 %	< 0.4	< 0.8

4-Tuning of PID controller using genetic algorithm approach :

GA is a stochastic global adaptive search optimization technique based on the mechanisms of natural selection. Recently, GA has been recognized as an effective and efficient technique to solve optimization problem. Compared with other optimization techniques. GA starts with an initial population containing a number of chromosomes where each one represents a solution of the problem which performance is evaluated by a fitness function. Basically, GA consists of three main stages: Selection, Crossover and Mutation. The application of these three basic operations allows the creation of new individuals which may be better than their parents. This algorithm is repeated for many generations and finally stops when reaching individuals that represent the optimum solution to the problem. The GA architecture is shown in Fig.5.[6]

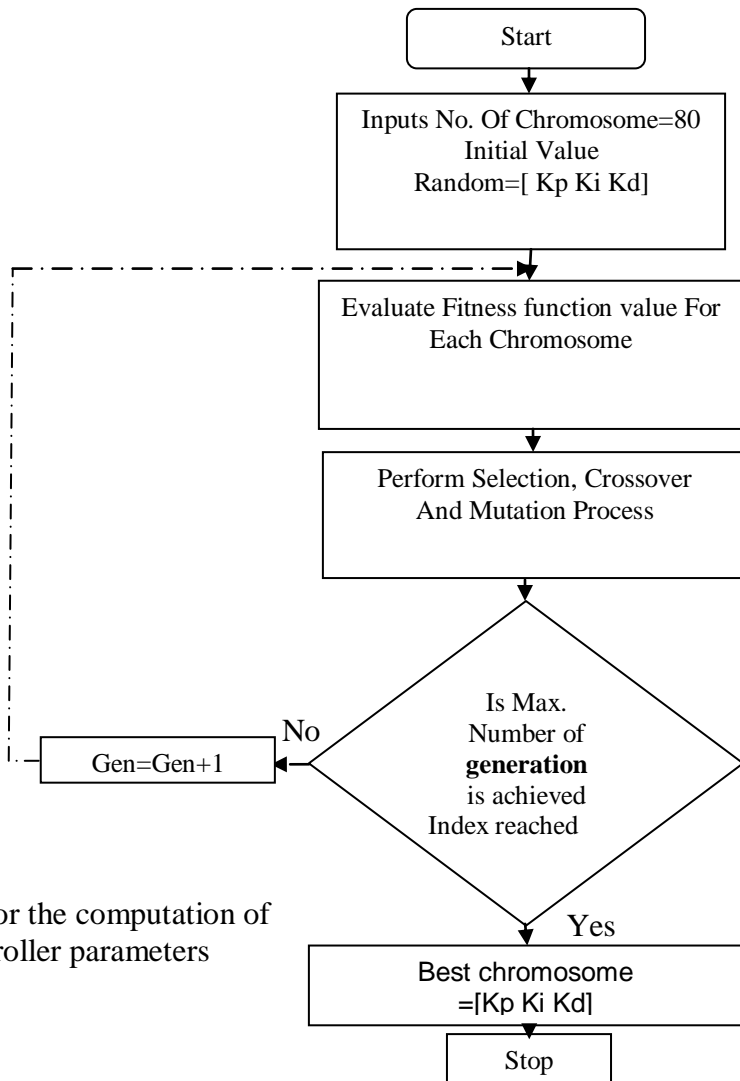

Fig.5. Simulation flow chart for the computation of GA-PID controller parameters

5-Genetic Algorithm For PID Tuning

The implementation of the tuning procedure through genetic algorithms starts with the definition of the chromosome representation. As illustrated in Fig.6 ,the chromosome is formed by three values that correspond to the three gains to be adjusted in order to achieve a satisfactory behavior. The gains K_p , K_i and K_d are real numbers and characterize the individual to be evaluated.[5]

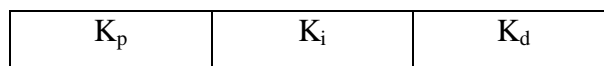

Fig.6 Chromosome Definition

The objective function is the calculation of its associated fitness. The fitness function is the measure of the quality of chromosome and can be defined as.

5-1 First Fitness Function (minimize the settling time, rise time and the overshoot):

Minimize J

Where,

$$J = \frac{1}{N} \sum_{i=1}^N e_i$$

N=3 and

$e_i = \{ts_{ga}/ts_{zn}, tr_{ga}/tr_{zn}, Mp_{ga}/Mp_{zn}\}$, where,

ts_{ga} is the settling time, tr_{ga} is the rising time and Mp_{ga} is the maximum over shoot

5-2 Second Fitness Function (minimize the settling Time only):

Minimize J

Where,

$$J = ts_{ga}$$

ts_{ga} is the settling time

5-3 Third Fitness Function (based on model reference approach):

Minimize J

Where,

$$J = \sum (y_m - y_s)^2 / M_{ax} t$$

y_s system response.

y_m model response.

$M_{ax} t = 500$ Sample

$$y_m = \begin{cases} t/(N_m-1) & \text{for } 0 \leq t < N_m \\ 1 & \text{for } t \geq N_m \end{cases}$$

$N_m = 21, 26, 31$ and 36 Sample

Note .Each 100 sample equal 1sec (sampling time =0.01sec).

6-Implementation Of GA Based PID Controller:

GA can be applied to the tuning of PID position controller gains to ensure optimal control performance at nominal operating conditions. The block diagram for the entire system is given in Fig.7 and also the genetic algorithm parameters chosen for the tuning purpose are shown Table 4.[7]

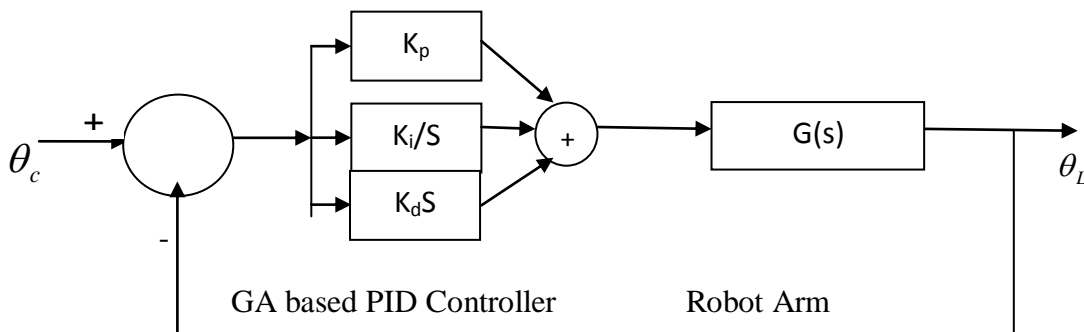

Fig.7 .Block Diagram Of The Entire System

Table 4. Parameters Of GA.[6]

GA property	Value/Method
Population Size	80
Maximum Number Of Generations	100
Performance Index/Fitness Function	Mean Square Error
Selection Method	Normalized Geometric Selection
Probability Of Selection	0.05
Crossover Method	Scattering
Mutation Method	Uniform Mutation
Mutation Probability	0.01

Considering the GA parameter of Table 4, together with fitness function explained in section 5.1 (minimize t_s, t_r and M_p) the step response is plotted in Fig.8. For comparison purposes, Fig.8 illustrates also, the system response under PID controller tuned using ZN method.

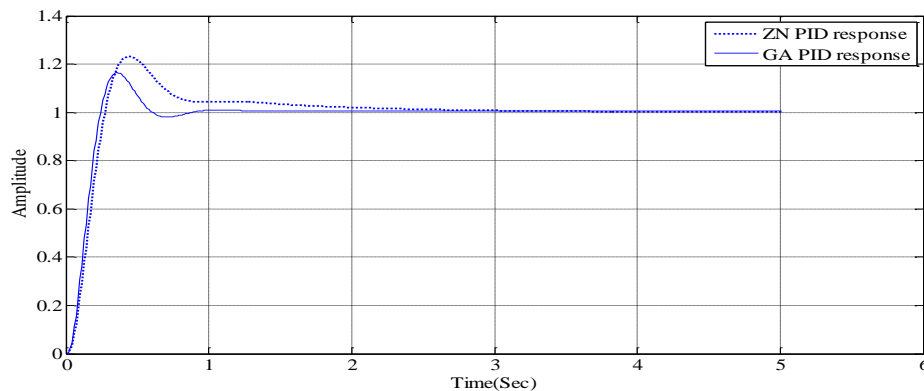

Fig 8. Step responses under PID controller tuned by GA (First Fitness Function) and Ziegler - Nichols' method (ZN) .

Furthermore, GA is used to tune the PID controller with the second fitness function given in section 5.2 (minimize t_s only). The system response is illustrated in Fig.9 together with that tuned by ZN for comparison.

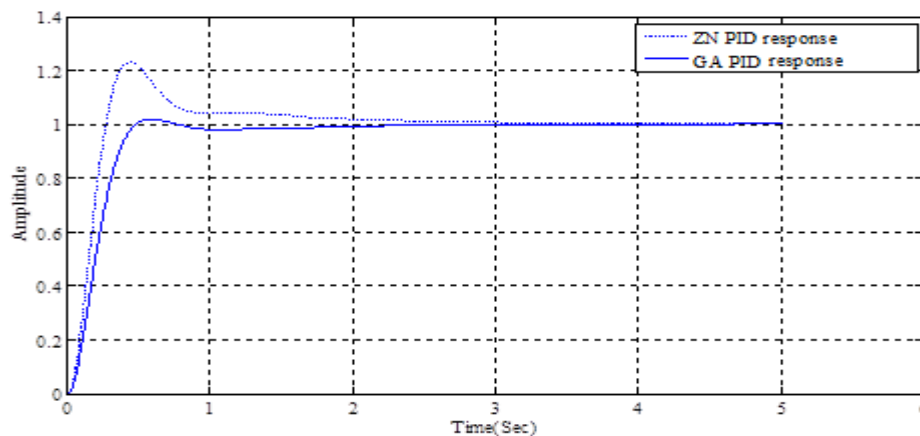

Fig 9. Step responses under PID controller tuned by GA (Second Fitness Function) and Ziegler - Nichols' method (ZN) .

Finally, the PID controller tuned by GA according to the third fitness function (section 5-3) is illustrated in Fig.10.

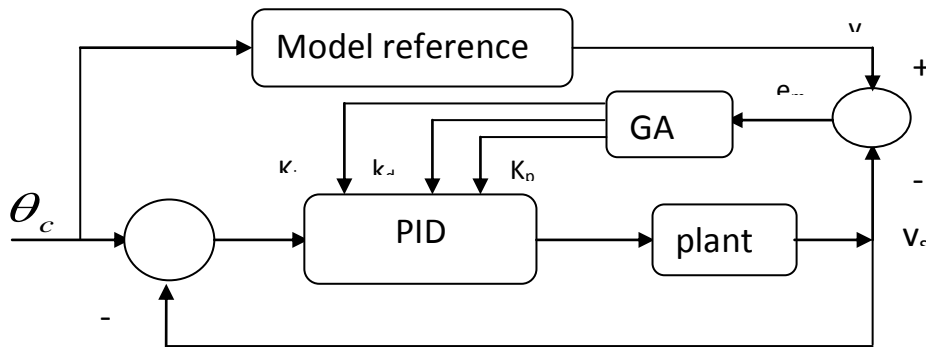

Fig.10 GA-tuned PID controller based on model- reference approach.

The following prescribed model references are used.

$$G_{m1} = \frac{583}{s^2 + 44s + 583} \quad \text{for } t_s = 0.2 \text{ sec}$$

$$G_{m2} = \frac{503}{s^2 + 44s + 503} \quad \text{for } t_s = 0.25 \text{ sec}$$

$$G_{m3} = \frac{444}{s^2 + 44s + 444} \quad \text{for } t_s = 0.3 \text{ sec}$$

$$G_{m4} = \frac{397}{s^2 + 44s + 397} \quad \text{for } t_s = 0.35 \text{ sec}$$

Figures 11 to 14, illustrate the GA-PID controller tuned according to 3rd fitness function (in a model reference context) using G_{m1} , G_{m2} , G_{m3} and G_{m4} as a model reference. Moreover ,the ZN tuned PID response is also plotted for comparison.

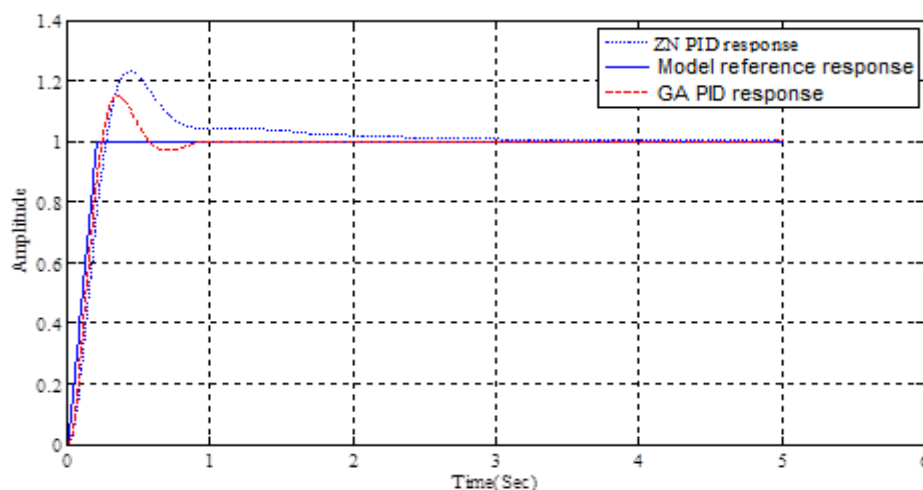

Fig 11. System response under GA-PID controller based on G_{m1} as a model reference.

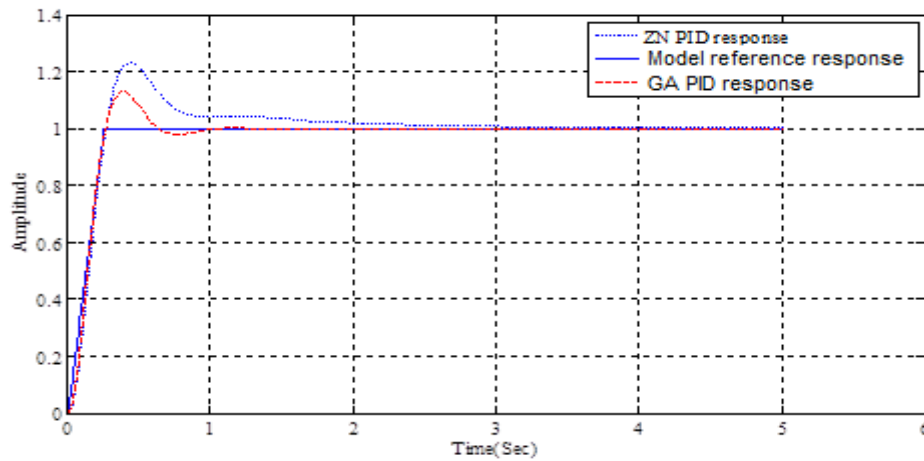

Fig 12. System response under GA-PID controller based on G_{m2} as a model reference.

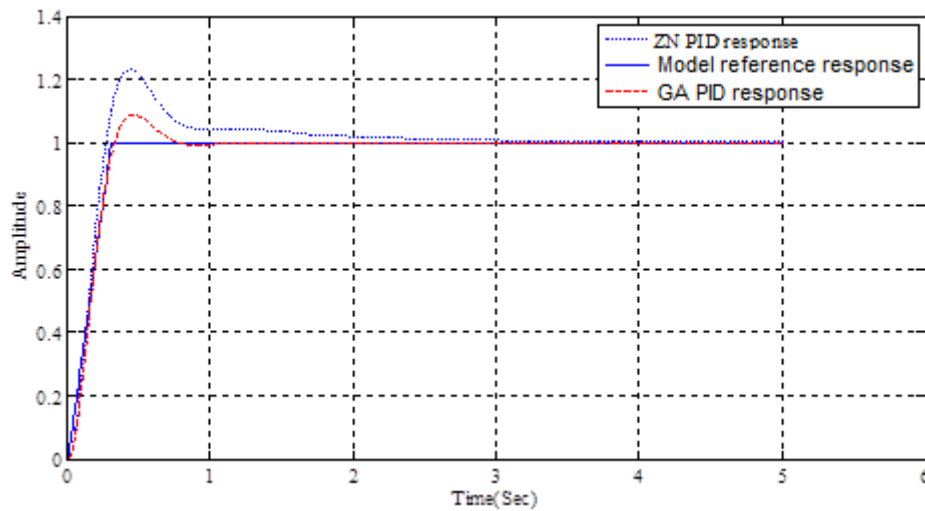

Fig 13. System response under GA-PID controller based on G_{m3} as a model reference.

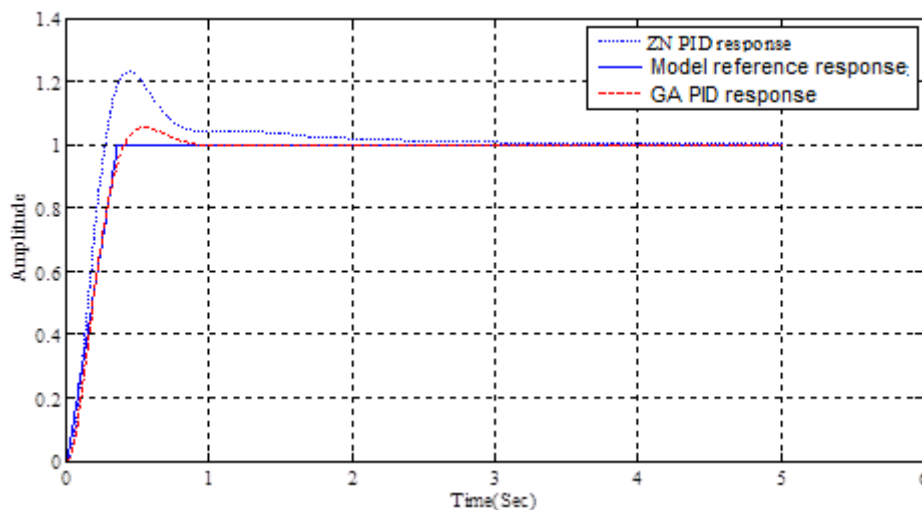

Fig 14. System response under GA-PID controller based on G_{m4} as a model reference.

7-Analysis Of Result:

Table 5 indicates the improvement of the GA-PID controller response in terms of minimizing the overshoot, the rise time and the settling time. One can easily notice that the improvements are achieved for the three selected fitness function explained in section 5. This variety of fitness functions gives a wide range of selectivity to the designer to choose the appropriate controller parameters that meets his/her requirements .

Table 5.Comparison Of Results

Tuning Method		K_p	K_i	K_d	Maximum Overshoot	Rise Time (Sec)	Settling Time(Sec)
ZN Method		15.8	7.18	8.68	23.9 %	0.2	2
Genetic Algorithm Approach							
First fitness function		11.3	0.92	11.5	16.43 %	0.157	0.556
Second fitness function		4.63	0.039	6.06	1.9 7 %	0.336	0.4358
Third fitness function	model-1	9.90	0.0617	11.5	14.27 %	0.1924	0.7933
	model-2	9.22	0.0305	10.1	13.02 %	0.1766	0.5860
	model-3	7.40	0.0125	7.95	8.84 %	0.2165	0.6798
	model-4	6.05	0.011	6.49	5.58 %	0.2614	0.7564

8-Conclusion:

The step responses under PID controller tuned by GA for three fitness functions are faster than that response under PID controller tuned by Zigler –Nichols .However, the ZN method is good for giving the designer the initial guess for the PID tuning. The step response under PID controller tuned by GA is better in terms of minimizing the max overshoot, the rise time and the settling time .Finally the mean square error associated with GA-PID controller is less than the error associated with conventional approach.

References:

- [1] K Ogata, "Modern Control Systems", University of Minnesota, Prentice Hall, 2003
- [2] T. O.Mahony, C J Downing and K Fatla,"Genetic Algorithm for PID Parameter Optimization: Minimizing Error Criteria", Process Control and Instrumentation 2000 26-28 July 2000, University of Strathclyde, pg 148- 153.
- [3] Q.Wang, P Spronck and R Tracht, "An Overview Of Genetic Algorithms Applied To Control Engineering Problems", Proceedings of the Second International Conference on Machine Learning And Cybernetics, 2003
- [4]K. Krishnakumar and D. E. Goldberg, "Control System Optimization Using Genetic Algorithms", Journal of Guidance, Control and Dynamics, Vol. 15, No. 3, pp. 735-740, 1992.
- [5]A. Varsek, T. Urbacic and B. Filipic, "Genetic Algorithms in Controller Design and Tuning", IEEE Trans. Sys.Man and Cyber, Vol. 23, No. 5, pp1330-1339, 1993.
- [6]Neenu Thomas,Dr.P.Poongodi "Position Control of DC Motor Using Genetic Algorithm Based PID Controller" Proceedings of the World Congress on Engineering 2009 Vol II WCE 2009, July 1 - 3, 2009, London, U.K.

- [7] Naeem, W., Sutton, R. Chudley. J, Dalglish, F.R. and Tetlow, S., . "An Online Genetic Algorithm Based Model Predictive Control Autopilot Design With Experimental Verification". International Journal Of Control, Vol 78, No. 14, pg 1076 . 1090, September 2005
- [8] L.phillips and D.Harbar, "Feedback Controller System ",3rd edition , Prentice Hall, 1996
- [9] Chun Htoo Aung, Khin Thandar Lwin, and Yin Mon Myint," Modeling Motion Control System for Motorized Robot Arm using MATLAB" World Academy of Science, Engineering and Technology 42, 2008

The work was carried out at the college of Engineering. University of Mosul